

ELECTRO-MECHANICAL GEARED SUB TERRAIN OPERATOR

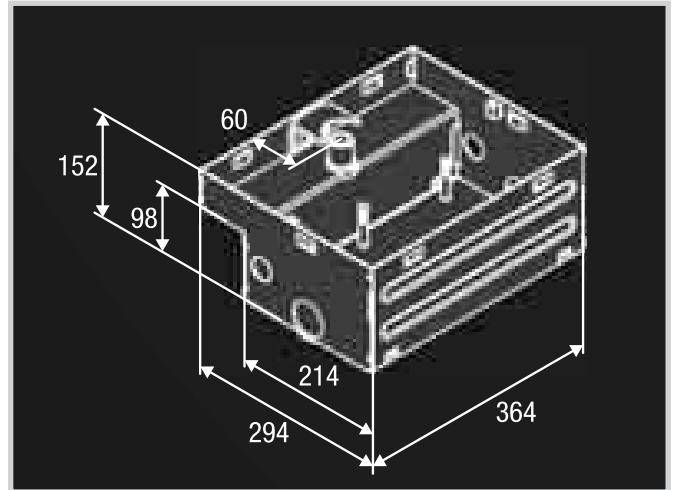
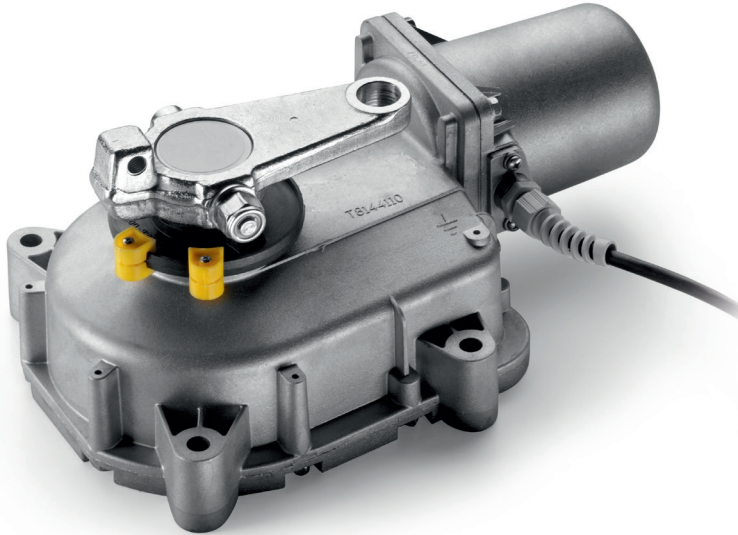

FEATURES

- **Self-locking electro-mechanical operator**
- **Reliable and strong reduction unit**
- **Mechanical components made of steel**
- **230 Vac**
- **Suitable for gates up to 3.50m per leaf**
- **Foundation boxes hot dipped galvanized**
- **Adjustable mechanical stops for open/close**
- **180° opening on request**

230 VAC CONTROL PANEL

- Control panel for 1 or 2 motors
- Step by step input
- Electronic force adjustment
- Diagnostics LCD display
- Built in 433.93Mhz radio receiver
- Electronic adjustment of torque and operating times for each motor
- Separate limit switch inputs to open/close each motor
- Separate slow down during open/close for each motor
- 8.2 Kohm safety edge input
- View actual number of cycles counter
- Programming access password

TECHNICAL DATA	IG.DUIT
Power supply	230 Vac (50-60Hz)
Motor supply	230 Vac
Max absorbed current	1.6 A
Torque	370 Nm
Opening time	22"
Operation cycle	30%
Protection level	IP67
Encoder	NO
Operating temperature	-20°C /+50°C
Leaf max dimension	3.5 m
Encoder	NO
Weight	11.6 kg