

## HALF HEIGHT TURNSTILE ROUND - J



With the modern design, reliable and cost-effective operation, high quality and robust construction the ROUND-J turnstile is the most favourite device in access control systems. Major parts made of stainless steel guarantee long durability of the ROUND-J turnstile even in harsh conditions.

The ROUND-J is an electronically controlled bi-directional 120° turnstile to ensure comfortable and safe access of one person. Depending on a way of identification it can achieve a maximum throughput of 20 people per minute. Typical access control configurations are card-in, card-out; card-in, free-out; card-in, locked-out.

Intelligent logic unit makes an operation of the turnstile custom flexible and ensures communication with various identification devices including push button control for remote control of the turnstile from reception desk or guard booth.

The turnstile ROUND-J together with the PEGAS gates create compact solution of access control system that meet security standards and ensure easy access for the handicapped.

The ROUND-J turnstile is supplied with following drive units:

### Electro-mechanical drive unit TE2, TE-NB

Operation of the tripod turnstile is controlled by an electro-mechanical mechanism with following standard features:

- A locking system with electromagnets that prevents two passages in one time
- A self centering mechanism to complete rotation of the turnstile into the home position
- A hydraulic shock absorber to ensure smooth and progressive slowing down operation
- A blocking mechanism that prevents from reverse rotation

Mechanical drive unit has got the same features as electro-mechanical one except there isn't a logic unit and other parts to control the turnstile. Such a turnstile is used for monitoring and directing of people.

### Motorised drive unit MT

High comfort, reliable and trouble-free operation are the priorities of the ROUND-J turnstile with motorised drive unit. The standard features are:

- Effective blocking system in combination with motorised drive unit
- Automatically set rotation speed according to a force the turnstile is pushed
- High level of personal security achieved by stopping the rotation if an obstacle is detected
- Very silent and smooth operation
- Adjustable slowing down of the turnstile

### Materials

Handrail and uprights:	AISI 304 Polished Stainless Steel tube, diameter 60 mm
Central pillar:	Electro-mechanical drive unit - painted black Motor drive unit - AISI 304 Polished Stainless Steel
Wing:	AISI 304 Stainless Steel tube, polished, diameter 40 mm

### Interface

The turnstile is controlled via the MLU 4V2 microprocessor logic unit. The standard features are as follows:

- One input for opening/closing the mechanism in each direction
- One protected input for unlocking of the turnstile in the event of an emergency
- Two multi-functional inputs ready for future purposes
- One output indicating actual status of the turnstile (BUSY signal)
- Four protected outputs for communication with LED Traffic lights
- Two outputs to check completed passage through the turnstile in certain direction
- Adjustable time out facility (range from 6s to 30s) to cancel GO signal if passage through the turnstile is not completed within the time

The logic unit is protected against overloads, short circuits and polarity inversion.

### Technical parameters

- Operating temperature: -30°C to +50°C
- Humidity: maximum 80%
- MCBF: 3.000.000 cycles (Mean cycle before failure)

### Turnstile with electro-mechanical unit

- Power supply: 24VAC/DC, 2A (external power source included)
- Shock absorber: Hydraulic adjustable
- Electromagnet: Duty cycle 100%

### Turnstile with motorised unit

- Power supply: 10 to 16VDC
- Power consumption: standby 0.1A, typical 2A, peak 3A

### Emergency

In the event of an emergency or power failure, rotor of the turnstile would freely turn in both directions.

## ACCESSORIES

### Push Button Control

- Remote control of turnstile
- Remote unlocking of the turnstile

### Alternative Materials, Finishes and Design

- Central pillar, handrail and uprights: Brushed Stainless Steel or Brass

### Outdoor design

- Automatic heating controlled by thermostat (necessary for turnstiles with electro-mechanical and motorised units)

### Back-up battery

- Back-up battery 12VDC/15Ah maintains turnstile with motorised drive unit for at least 6 hours of continues operation

### Identification systems

- Easy integration and installation of card reader devices: barcode, magnetic card, proximity card, smart card, biometrics, coin/token acceptors

ROUND-J - MT

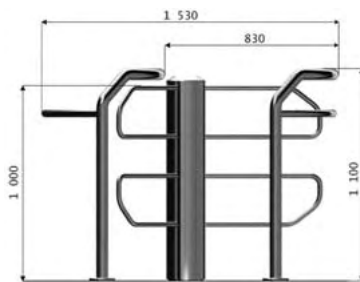

ROUND-J - MT

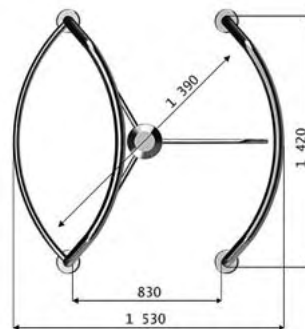

ROUND-J - TE2

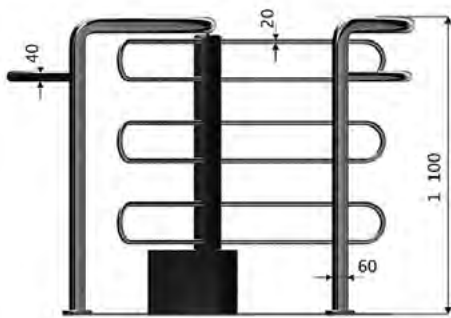

ROUND-J - TE2

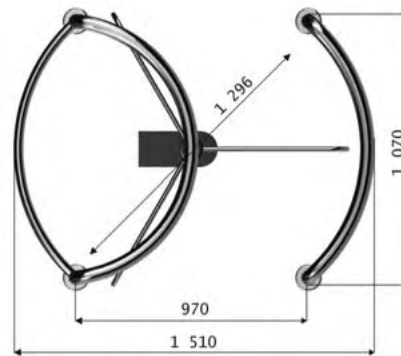

 **cominfo**® a.s.

Cominfo, a.s.  
Lešetin II/651  
760 01 Zlín  
Czech republic  
Tel.: +420 577 618 240, +420 577 618 219  
Fax: +420 577 618 239  
E-mail: [cominfo@cominfo.cz](mailto:cominfo@cominfo.cz)  
[www.cominfo.cz](http://www.cominfo.cz)

